

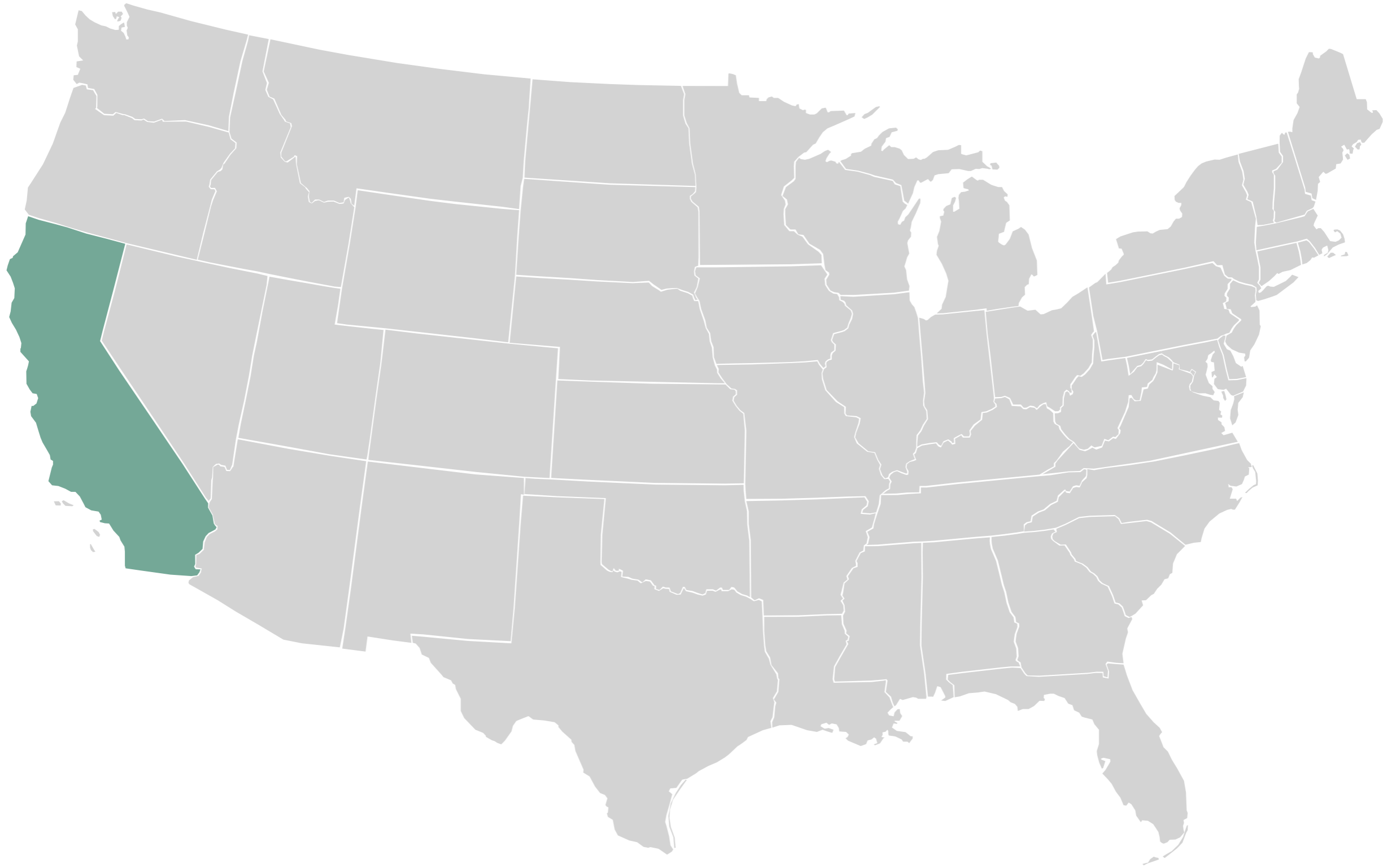

GRAPHIC DESIGN FOR WORSHIP & OUTREACH

National Conference on Worship, Music, & the Arts







opus S4



SIDE VIEW

FORWARD PHASER BANKS

BRIDGE

PRIMARY DOCKING PORT

OFFICER'S LOUNGE

IMPULSE ENGINE

WARP NACELLE

MAGNATOMIC FLUX CONTRICTION-FIRST STAGE

MAGNATOMIC AMPLIFICATION CRYSTAL

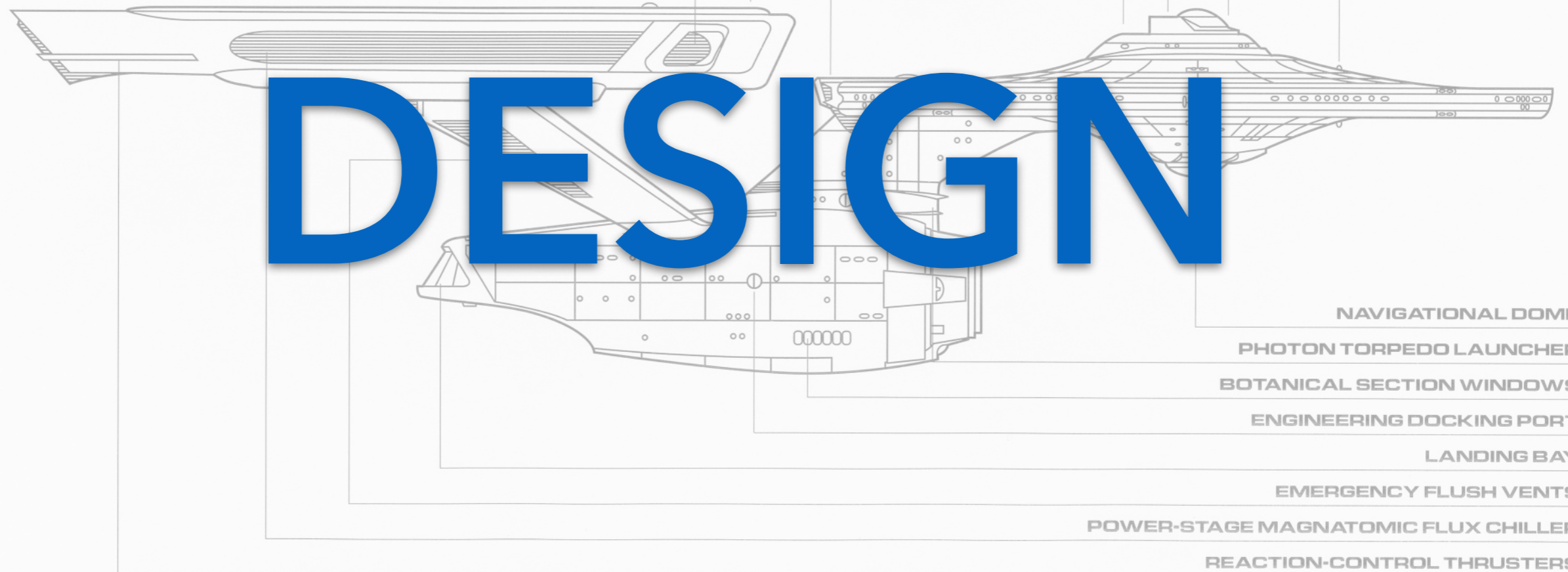

NAVIGATIONAL DOME

PHOTON TORPEDO LAUNCHER

BOTANICAL SECTION WINDOWS

ENGINEERING DOCKING PORT

LANDING BAY

EMERGENCY FLUSH VENTS

POWER-STAGE MAGNATOMIC FLUX CHILLER

REACTION-CONTROL THRUSTERS

STAR TREK®

**U.S.S. ENTERPRISE
NCC-1701-A**

The STARSHIP U.S.S. ENTERPRISE NCC-1701-A maintains extensive weapons capabilities and transport facilities.

Its new design increases phaser power by channeling direct power from the warp-drive system. Photon torpedoes are on a separate system to prevent overloading and act as an emergency back-up in case of phaser loss. The new U.S.S. ENTERPRISE provides cumulative radiation exposure shields for transporter personnel.

SIDE VIEW

FORWARD PHASER BANKS

BRIDGE

PRIMARY DOCKING PORT

OFFICER'S LOUNGE

IMPULSE ENGINE

WARP NACELLE

MAGNATOMIC FLUX CONTRICTION-FIRST STAGE

MAGNATOMIC AMPLIFICATION CRYSTAL

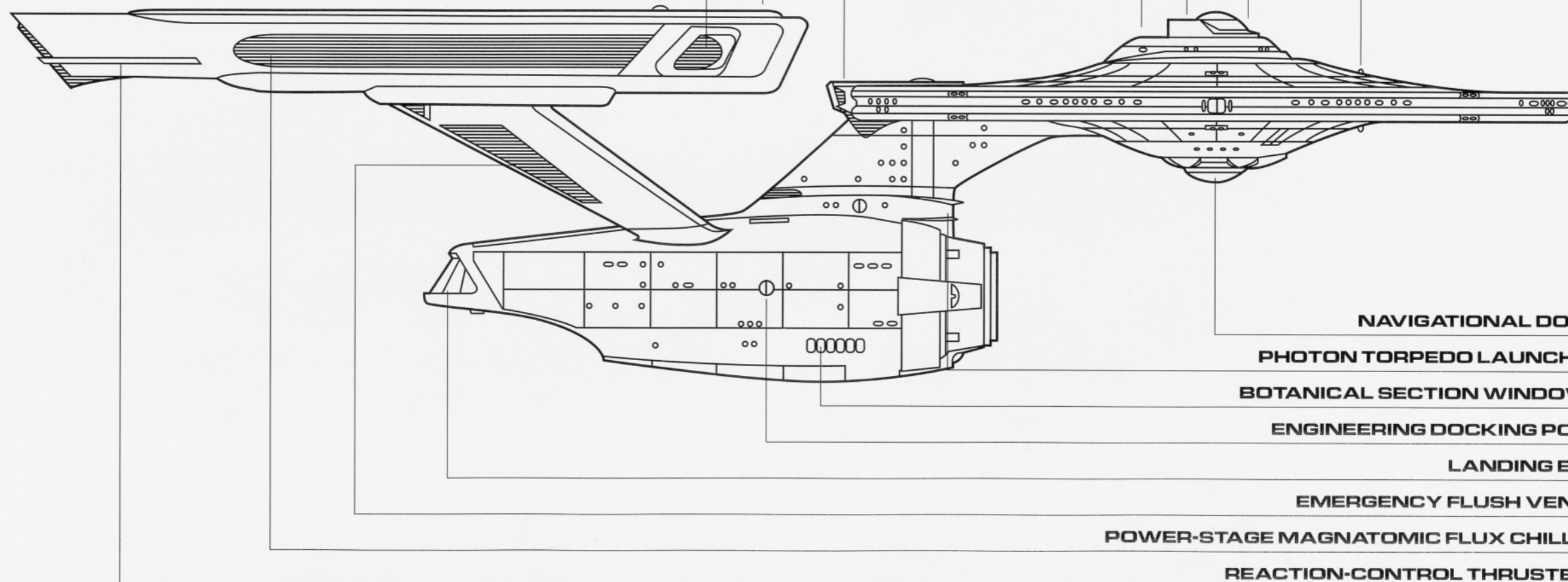

STAR TREK®

U.S.S. ENTERPRISE NCC-1701-A

The STARSHIP U.S.S. ENTERPRISE NCC-1701-A maintains extensive weapons capabilities and transport facilities.

Its new design increases phaser power by channeling direct power from the warp-drive system. Photon torpedoes are on a separate system to prevent overloading and act as an emergency back-up in case of phaser loss. The new U.S.S. ENTERPRISE provides cumulative radiation exposure shields for transporter personnel.

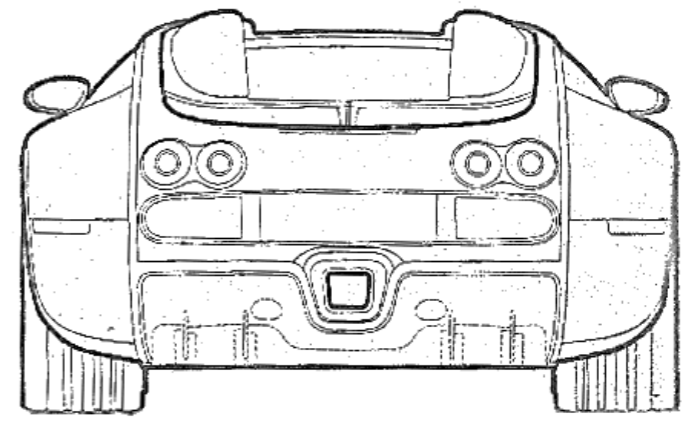
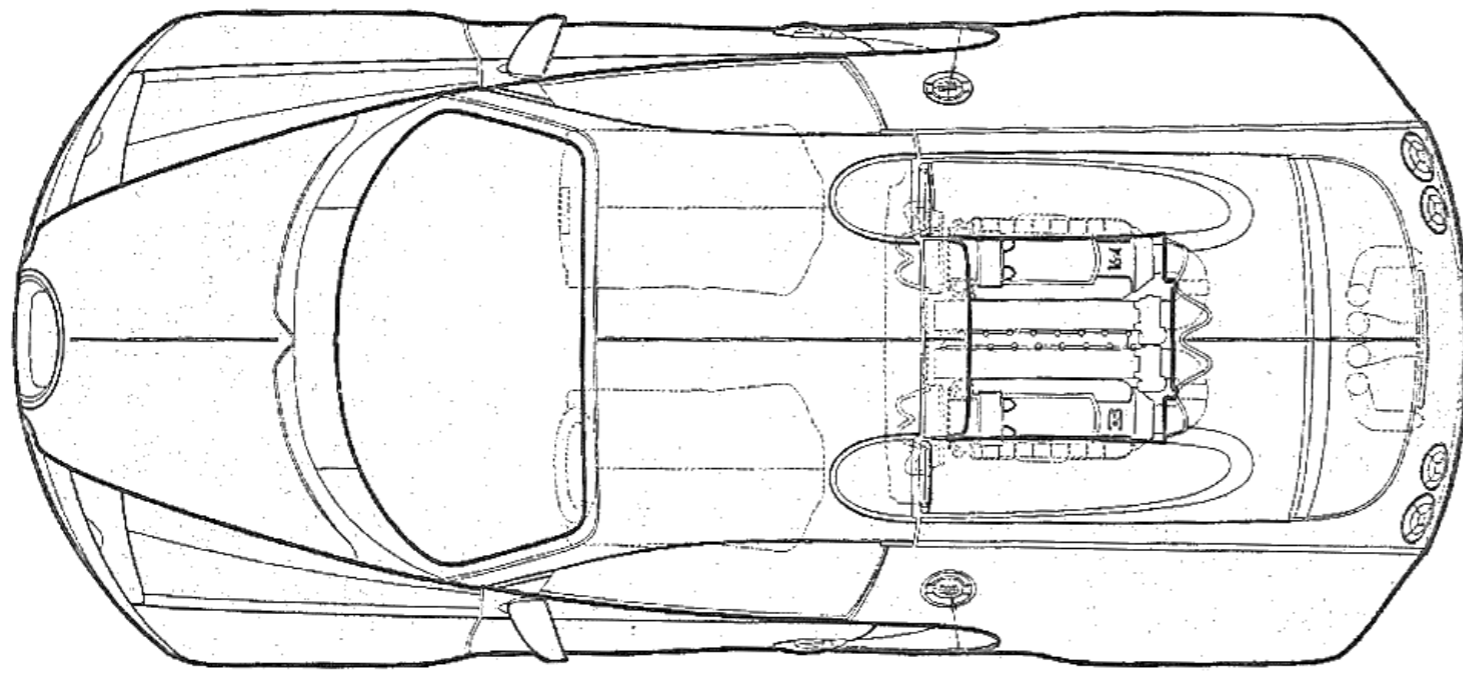
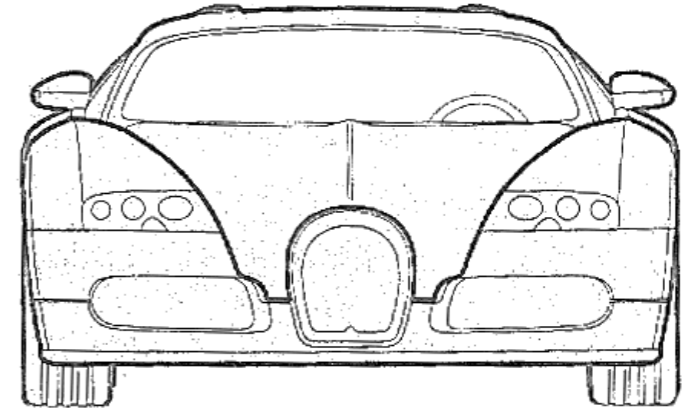
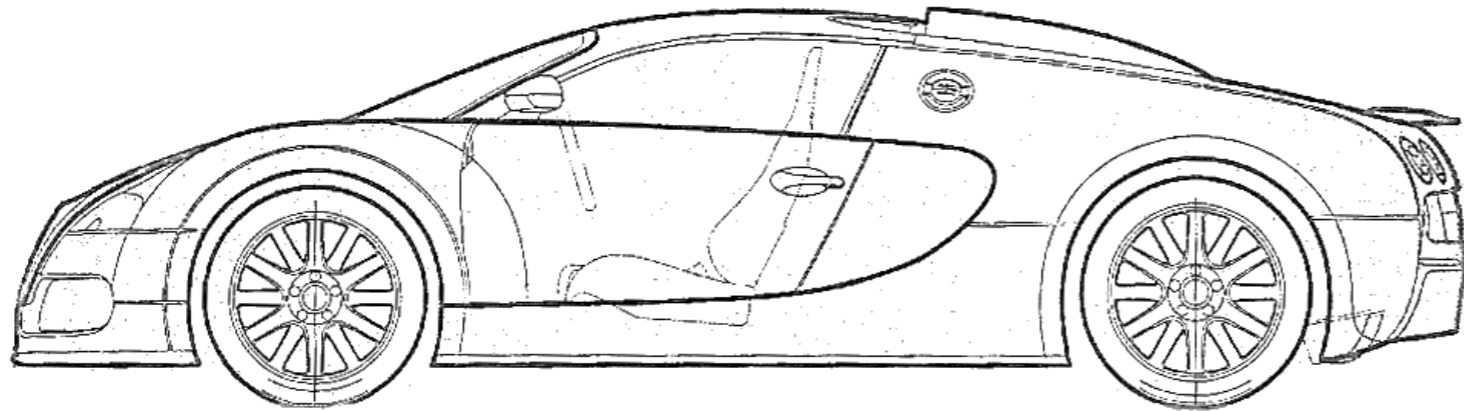

A plan or drawing produced to show the look and function or workings of a building, garment, or other object before it is made.



translating an **idea**

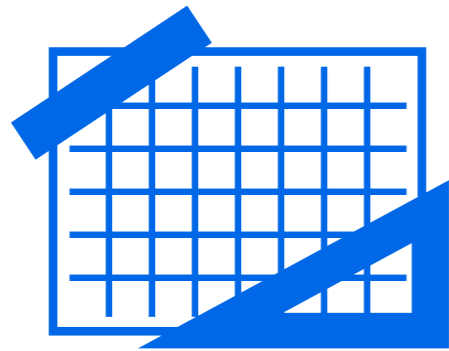

into a **blueprint**



for **something useful**

GRAPHIC DESIGN

Visual Communication



Think small.

Our little car isn't so much of a novelty any more.
A couple of dozen college kids don't try to squeeze inside it.
The guy at the gas station doesn't ask where the gas goes.
Nobody even stares at our shape.
In fact, some people who drive our little

river don't even think 32 miles to the gallon is going any great guns.
Or using five pints of oil instead of five quarts.
Or never needing anti-freeze.
Or racking up 40,000 miles on a set of tires.
That's because once you get used to

some of our economies, you don't even think about them any more.
Except when you squeeze into a small parking spot. Or renew your small insurance. Or pay a small repair bill.
Or trade in your old VW for a new one.
Think it over.



LIFE SPECIAL EDITION

TO THE MOON AND BACK



\$1.50

A magazine cover for LIFE magazine's Special Edition. The main image is a photograph of an astronaut in a white space suit standing on the moon's surface. The astronaut's helmet visor reflects the lunar landscape and another astronaut in the distance. The magazine title "LIFE" is in a red box at the top left, and "SPECIAL EDITION" is at the top right. The headline "TO THE MOON AND BACK" is in large white letters on the left. The price "\$1.50" is at the bottom left.

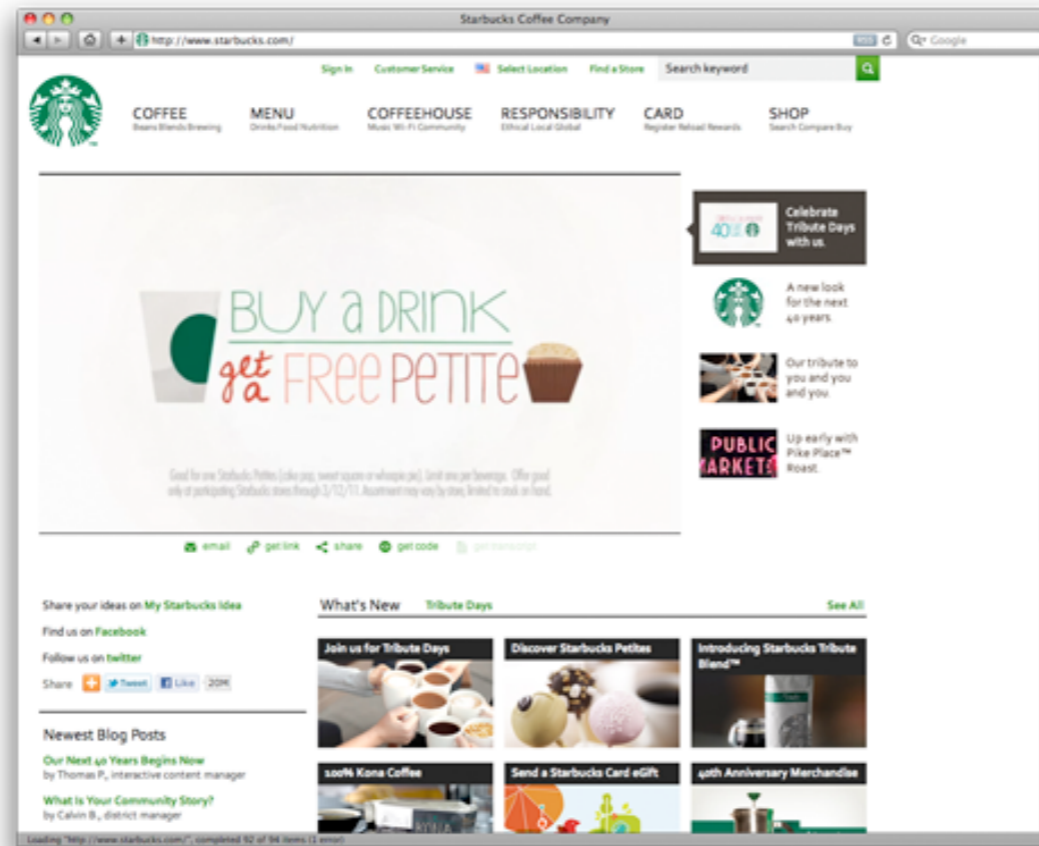

Logo Variations

Starbucks logo is composed of the Siren symbol and the Starbucks wordmark.

preferred use is for the Siren symbol wordmark to be unlocked. This idea flexibility to present the Siren bol with greater prominence while retaining a considered, open and airy presentation.

locking should be used for third-party locations (e.g., sponsorship activities) that legally require (e.g., use with graphics). Please contact our Starbucks and Corporate Affairs Department for clarification.

When the Siren symbol and wordmark are unlocked, the wordmark is always black or white on a background. The unlocked wordmark may be placed vertically, reading upward.

Do not use the unlocked Siren bol and wordmark in proximity to other.

In the locked configuration, the bol and wordmark maintain a fixed size, and the size relationship may not be used.



Color Palette

Color plays a critical role in the way that we express our brand. We've created a system that is broad enough to provide flexibility, but is still carefully honed and narrowed to reinforce consistency. Together with the primary palette, the top rows of secondary and accent colors are always preferred. This palette contains the only colors to be used in the expression of our brand.



Photography—Product Moments

Product moments focus exclusively on our products. Although human presence is not visible in the composition, it can be implied through the use of natural warm colors, selective focus and asymmetry.

Use product photography in in-store applications such as banners, sidewalk A-frames, menu boards, daily offerings boards, drive-thru panels and online thumbnails.

Note: All photography should reflect evidence of our brand, avoid images that could be any brand.

Note: All imagery examples throughout these guidelines are for illustrative purposes only. They have not been approved for use in other communications.

Considerations: Show the texture of ingredients through composition. The 'season' is the hero, so the focus is on the product.



conuersi dirumpant uos
Pace & claritate uobis querite
 inuenietis pulsate & aperietur uobis
 omnis enim qui per uiam accipit
 & qui uenerit inuenit & pulsata ap

Autem praegnantibus
 inuenietis in illis diebus
Ute autem ueniat fuga
 uestra hinc uel sabbato
Propterea inuenietis in illis
 quibus non fuit ab initio
 di usque in modo neque
Quasi breuia fuissent dies
 illi non fieret salua om-
 nis caro sed propter electos bre-
 uia ueniet dies illi
Tunc si quis uobis dixerit ecce
 hic est Christus uolte credere

parat est uis filius meus dilectus in ce-
 bene complacuit mihi
Quod ipse in seruitute inueniens quasi a-
 uorum triginta uocabatur filius
 ioseph
M pater heu
VI pater macha
VI pater leui
VI pater melchi
VI pater iacob
VI pater ioseph
VI pater macha hic
VI pater anos
VI pater iacob
VI pater esu
VI pater magge
VI pater enaach

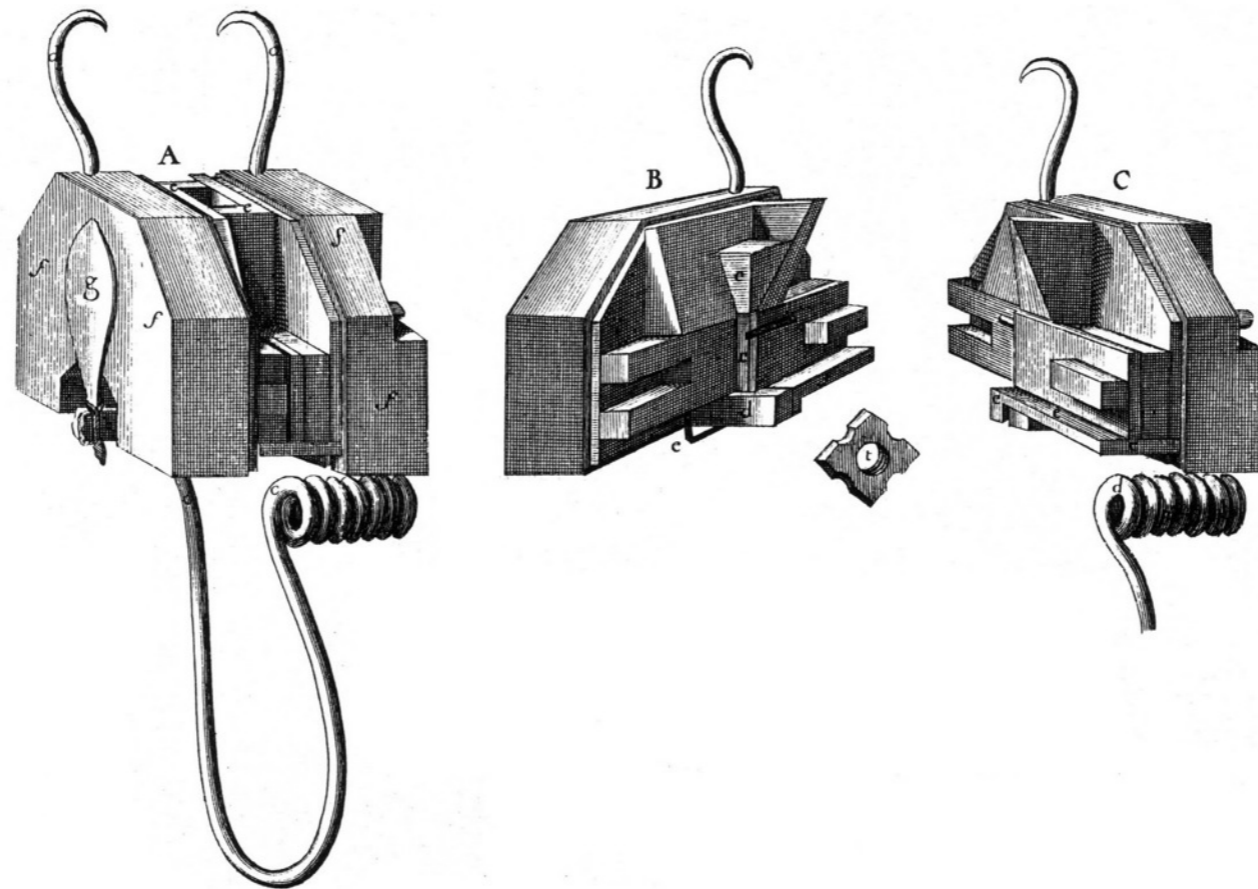
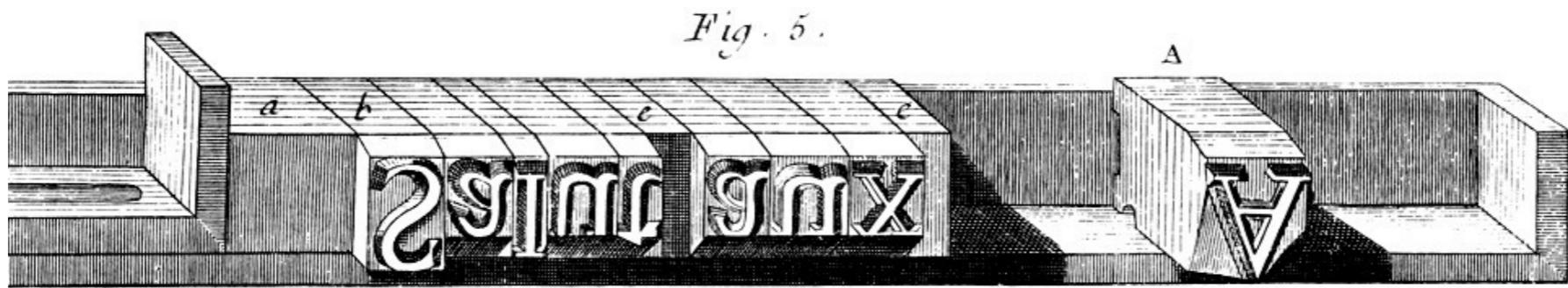
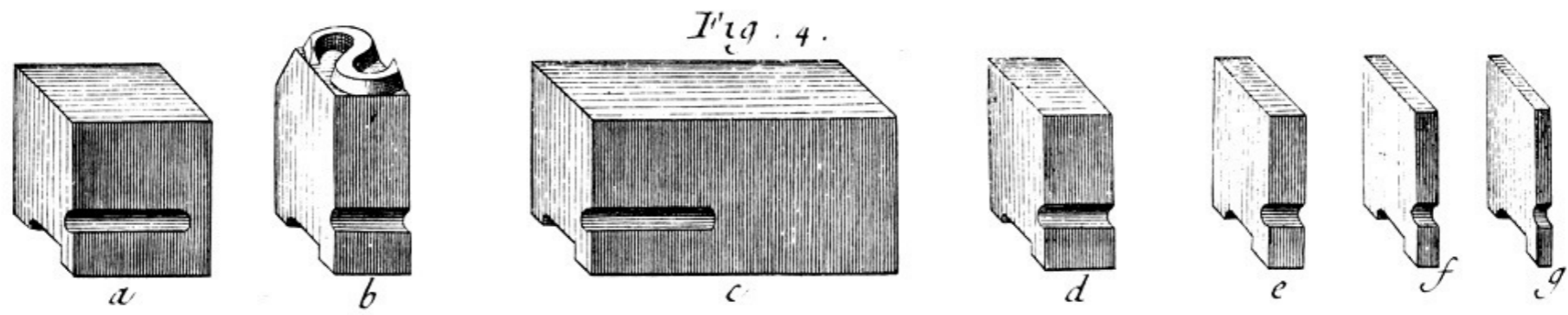



THE NATIVITY OF OUR LORD, OR THE BIRTHDAY OF CHRIST, COMMONLY CALLED CHRISTMAS-DAY.

THE COLLECT.



ALMIGHTY God, who hast given us thy only-begotten Son to take our nature upon him, and as at this time to be born of a pure virgin; Grant that we being regenerate, and made thy children by adoption and grace, may daily be renewed by thy Holy Spirit; through the same our Lord Jesus Christ, who liveth and reigneth with thee and the same Spirit ever, one God, world without end.

Amen.

THE EPISTLE. Heb. i. 1.



OD, who at sundry times and in divers manners spake in time past unto the fathers by the prophets, hath in these last days spoken unto us by his Son, whom he hath appointed heir of all things, by whom also he made the worlds; who being the brightness of his glory, and the express image of his person, and upholding all things by the word of his power, when he had by himself purged our sins, sat down on the right hand of the Majesty on high; being made so much better than the angels, as he hath by inheritance obtained a more excellent name than they. For unto which of the angels said he at any time, Thou art my Son, this day have I begotten thee? And again, I will be to him a Father, and he shall be to me a Son? And again, when he bringeth in the firstbegotten into the world, he saith, And let all the angels of God worship him. And of the angels he saith, Who maketh his angels spirits, and his ministers a flame of fire. But unto the Son he saith, Thy throne, O God, is for ever and ever: a sceptre of righteousness is the sceptre of thy kingdom. Thou hast loved righteousness, and hated iniquity; therefore God, even thy God, hath anointed thee with the oil of gladness above thy fellows. And, Thou, Lord, in the beginning hast laid the foundation of the earth; and the heavens are the works of thine hands: they shall

ADAM-PROTOPLAS
TVS-ABRAHAM-PAT-
RIARCHA-MOYSES-LEG-
ISLATOR-DAVID-REX

ISAIAS-PROPHETA
JEREMIAS-PROPHETA
DANIEL-PROPHETA
EZECHIEL-PROPHETA

SIBYLLA-PERSICA
SIBYLLA-LYBICA
SIBYLLA-ERYTHREA
SIBYLLA-DELPHICA
SIBYLLA-CYMANA



THE NATIVITY OF OUR LORD, OR THE BIRTHDAY
OF CHRIST, COMMONLY CALLED CHRISTMAS-DAY.

THE COLLECT.



ALMIGHTY God, who hast given us thy
only-begotten Son to take our nature upon
him, and as at this time to be born of a pure
virgin; Grant that we being regenerate, and
made thy children by adoption and grace,
may daily be renewed by thy Holy Spirit;
through the same our Lord Jesus Christ, who
liveth and reigneth with thee and the same
Spirit ever, one God, world without end.

Amen



ADAM·PROTOPLAS-
TVS·ABRAHAM·PAT-
RIARCHA·MOYSES·LEG-
ISLATOR·DAVID·REX

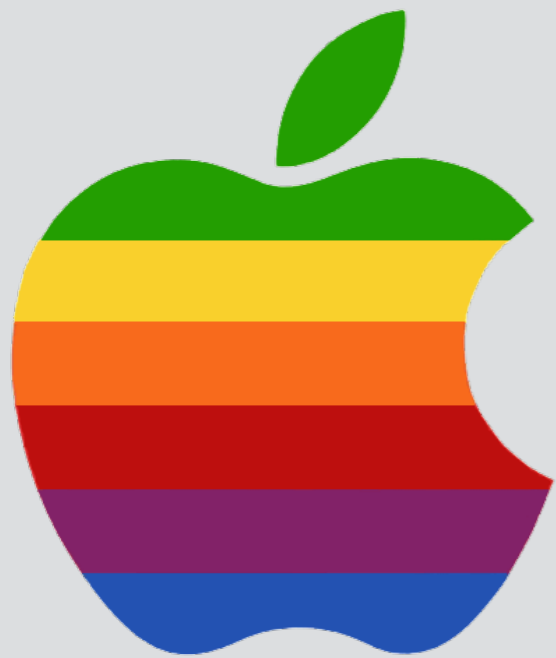

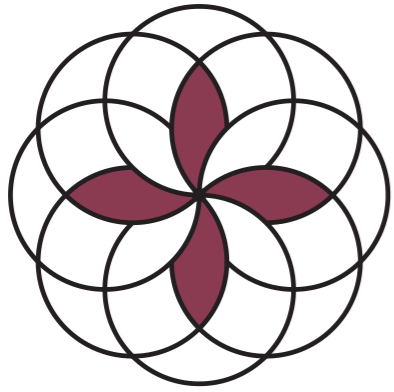



Beautiful Savior

1234 Wartburg Ave
Summerville, SC 76543



Beautiful Savior

EVANGELICAL LUTHERAN CHURCH



Jonathan Hein
Pastor

Beautiful Savior Lutheran Church
1234 Wartburg Ave
Summerville, SC 76543

Serving all people with the
Gospel of Jesus Christ as
revealed in the Holy Scriptures

123.456.7890
123.098.7654
email@churchname.com
churchname.com
facebook.com/churchname



Beautiful Savior



Beautiful Savior

1234 Wartburg Ave
Summerville, SC 76543

John Smith
567 Luther St
Summerville, SC 76543

Dear Sir,

Lorem ipsum dolor sit amet, consectetur adipiscing elit. Donec scelerisque ligula vitae enim vehicula a porttitor dui vulputate. Cum sociis natoque penatibus et magnis dis parturient montes, nascetur ridiculus mus. Cras sed diam erat, a blandit elit. Nam nec purus sed nunc sollicitudin porta. Donec ac suscipit quam. Integer pulvinar mollis nisi ut aliquam. Maecenas venenatis ipsum eget orci pretium suscipit.

Nulla fermentum lectus eget justo hendrerit sit amet imperdiet tortor porttitor. Nunc egestas lobortis odio nec feugiat. Integer mollis bibendum feugiat. Morbi blandit dolor ac turpis varius eget imperdiet ligula porttitor. Nulla facilisi. Praesent tincidunt dolor purus, porta sodales tellus. Etiam et diam at leo posuere condimentum. Suspendisse venenatis elit adipiscing leo laoreet sit amet porttitor leo mattis.

Nunc pharetra convallis lacus in ultrices. Aenean aliquam laoreet consectetur. Vestibulum tempor dignissim arcu quis tristique. Nullam quis neque nec tincidunt consequat et vitae leo. Vestibulum eu enim sit amet lorem cursus. Suspendisse quis orci at nulla dapibus interdum. Mauris vestibulum odio eget massa molestie ut laoreet libero tincidunt.

Sincerely,

churchname.com | email@churchname.com | 123.456.7890



Welcome!

The logo at the top of this page says a lot about our congregation. The name Zion is common in the Scriptures. In the Psalms, Zion often describes the Temple Mount built on a hill in Jerusalem where God dwelt among his people and where they gathered to worship him. For this reason, the term "Mount Zion" is often used. By extension, Zion can mean Jerusalem, Israel, and in the New Testament, God's people here and in eternity - in other words, the Holy Christian Church, where God is graciously present through the Gospel in Word and Sacrament.

The name Zion calls to mind mountains and solid rock. That's who we are - God's forgiven people founded on the solid rock of Jesus Christ who is revealed in the Holy Scriptures. The truth of his saving love is what we are all about. Serving him in thanks for that love is our greatest joy. We would love to grow in him with you. Please join us! You are always welcome!

Sunday Morning Worship

7:45 AM & 10:00 AM

9:00 AM - Adult Bible Study (childcare provided)

Thursday Evening Worship

6:30 PM

TV Service Schedule

Zion's worship services are available locally on cable channel 10. Monday-Thursday at 3:00 PM.



BIBLE-BASED GUIDANCE

Zion's pastors speak on the level of the listeners, using contemporary anecdotes and compelling illustrations to give messages of God's love and guidance. The message at Zion communicates God's Word in a way that 21st century people appreciate and understand.



CHRIST-CENTERED WORSHIP

The relevance of our Bible-based messages will guide you with new insight for the week ahead. The mercy of God through Jesus Christ and the meaning of faith make worship at Zion a reverent and relevant experience.



LIFE-RELATED BIBLE LEARNING

We offer opportunities to gain an understanding of God's Word. We cater to a variety of knowledge and interest levels, and make the study of God's Word a fun and enjoyable experience.



RISEN SAVIOR LUTHERAN CHURCH



Welcome to all - both visitor and member alike! May our ever-giving and gracious God fill your heart with joy, peace and hope through the message of forgiveness in our living Savior, Jesus Christ!

Risen Savior is part of a group of more than 1200 churches called the Wisconsin Evangelical Lutheran Synod or WELS with congregations in all fifty states, as well as Canada and Mexico. The WELS also serves over 26 other countries through world mission work. To learn what we believe please arrange a visit with our pastor or view our brief [statement of belief](#).

DIVINE SERVICE

The Lutheran church is a liturgical church. Lutherans believe that the gospel is not only good news that Jesus has saved sinners, but also a power God uses to create and strengthen faith in Jesus. Lutheran worship places the gospel in central focus in an order of service called the liturgy. In message and meal (Holy Communion), in specially selected Bible readings, and in carefully crafted songs, prayers, and confessions, the liturgy points to Jesus as the Savior of all.

OPENING HYMN

How Lovely Shines The Morning Star | 79 (1-2)

INVOCATION

please stand

M In the name of the Father and of the ☩ Son and of the Holy Spirit.

E Amen.

CONFESSION

M Arise, shine, for your light has come, and the glory of the Lord rises upon you.

E The Word became flesh and made his dwelling among us. We have seen his glory, the glory of the One and Only, who came from the Father, full of grace and truth.

M Brothers and sisters in Christ, the glory of God has come into our world. Through Jesus Christ God has revealed his glory to us, and by the power of the Holy Spirit, we have been claimed by God to be his children. Yet we have not lived as God's children ought to live.

E All of us have sinned and fall short of the glory of God.

M Most merciful God,

E we are not worthy to be called your children. So often we have chosen to live in the darkness of sin rather than to reflect your glory in our lives. We have not loved you with our whole heart. We have not loved others as we ought. We have sinned against you in our thoughts, in our words, and in our actions. Have mercy on us, kind Father, for the sake of Jesus Christ. "Help us, O God our Savior, for the glory of your name; deliver us and forgive our sins for your name's sake."

M The good news is that before we were even aware of our sin and need for forgiveness, God sent his only Son into this world made dark by sin. He came among us as one of us, lived the perfect sinless life in our place, and died for us on the cross that we deserved. By his death the penalty for our sins was paid, and in his glorious resurrection we are assured of the gift of new life. As a called servant of the Word, and at the command and promise of our Lord Jesus Christ, I forgive you all your sins in the name of the Father and of the Son and of the Holy Spirit.

E From him and through him and to him are all things. To him be the glory forever! Amen.

GLORY BE TO GOD

All Praise to God Who Reigns Above | 236

All praise to God who reigns a - bove, The God of
I cried to him in time of need: Lord God, oh,
all cre - a - tion, The God of won - ders pow'r and
hear my call - ing! For death he gave me life in -
love. The God of our sal - va - tion! With heal - ing
deed And kept my feet from fall - ing. For this my
halm my soul he fills, The God who ev - 'ry sor - row
thanks shall end - less be, Oh, thank him, thank our God with
with me To God all praise and glo - ry!
me To God all praise and glo - ry!

PRINCIPLES

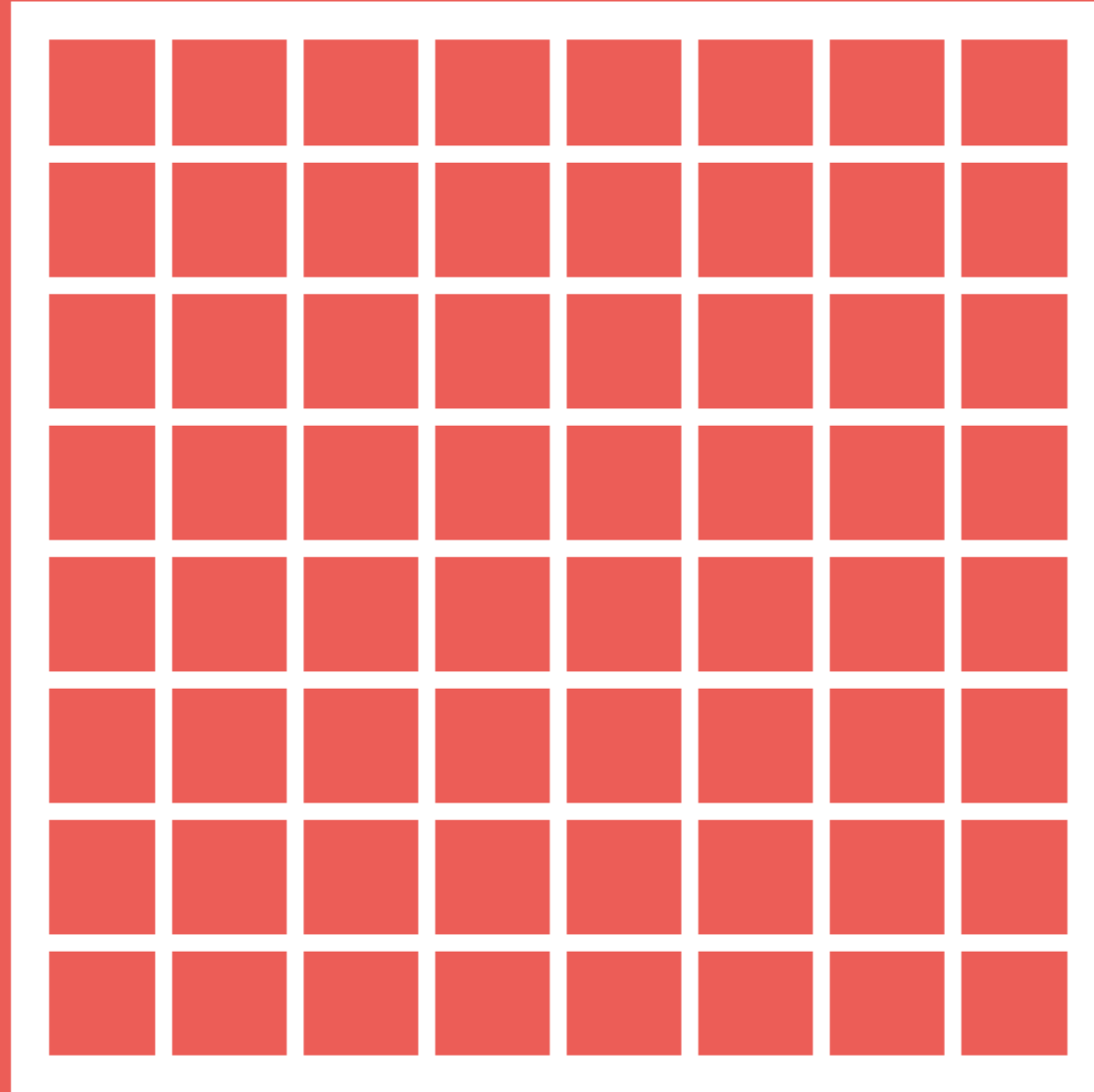

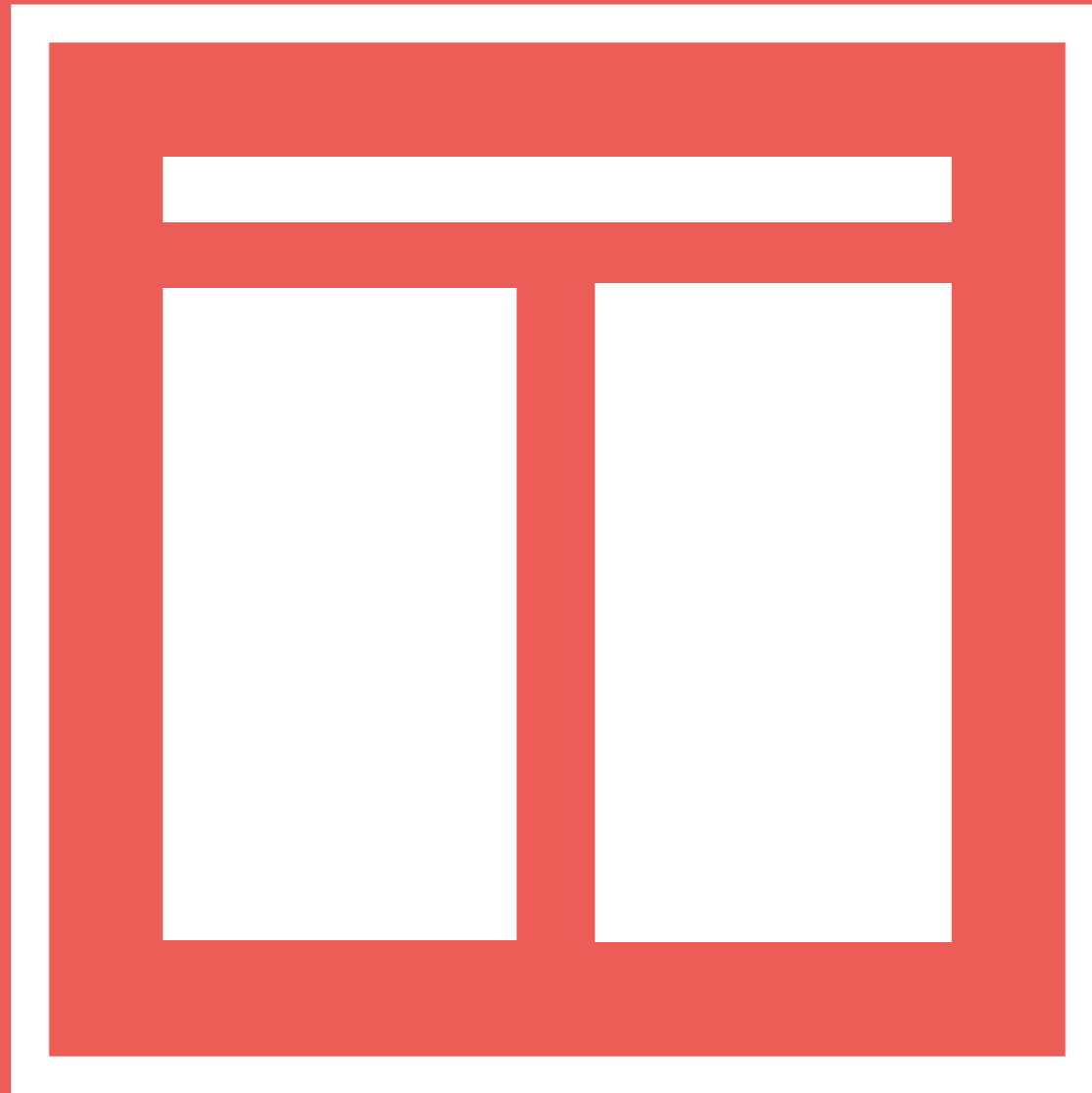

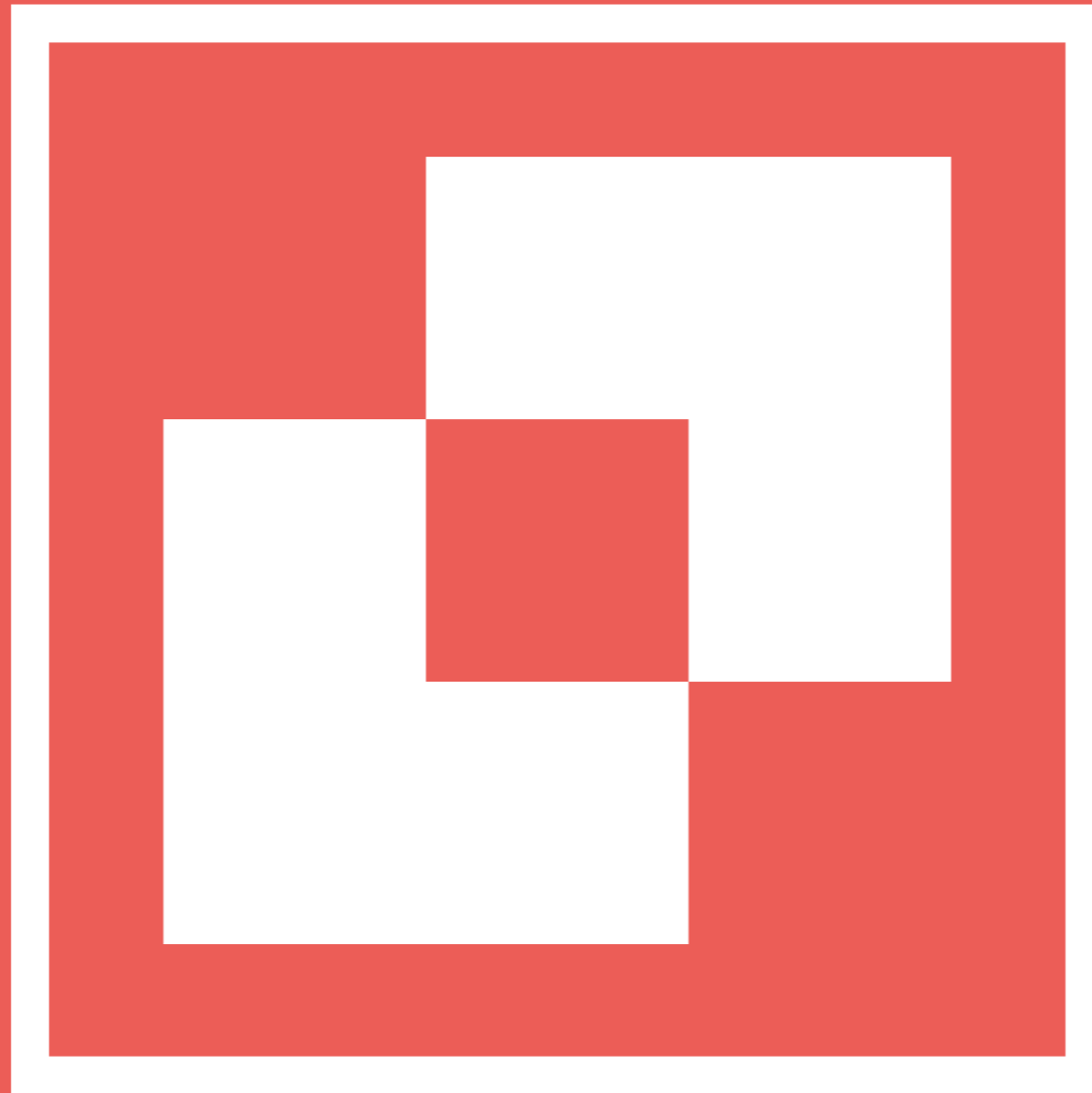

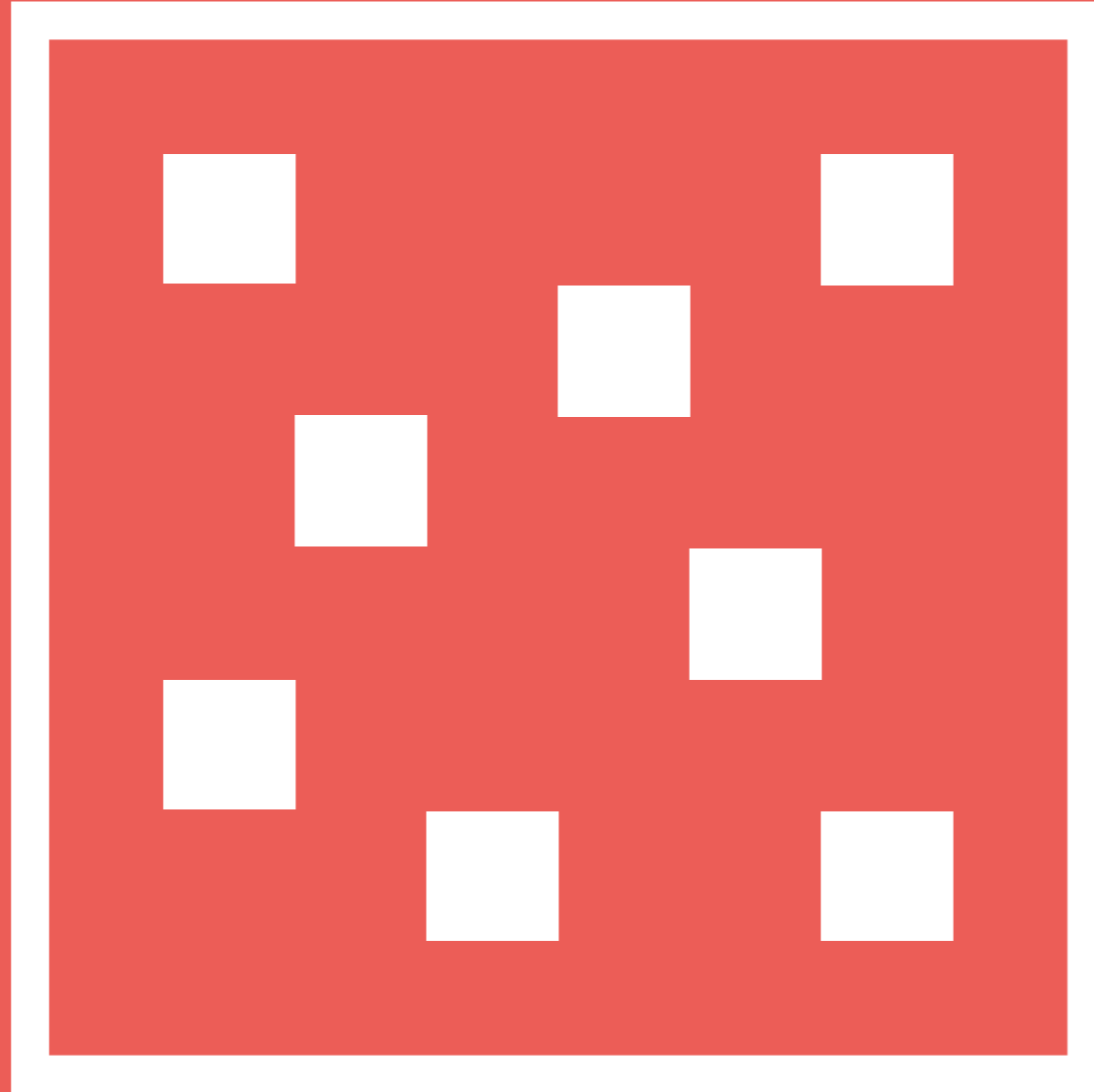

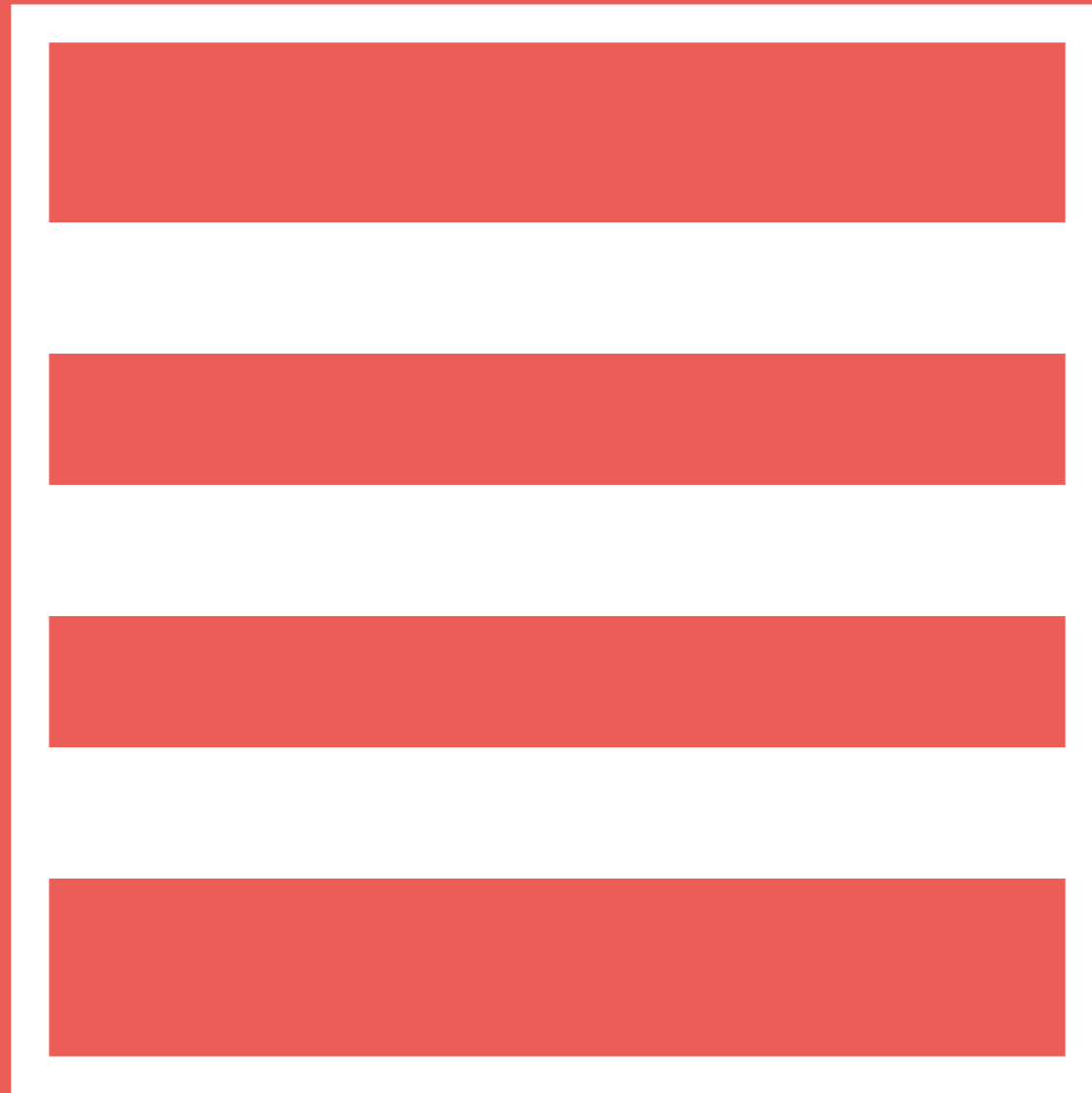

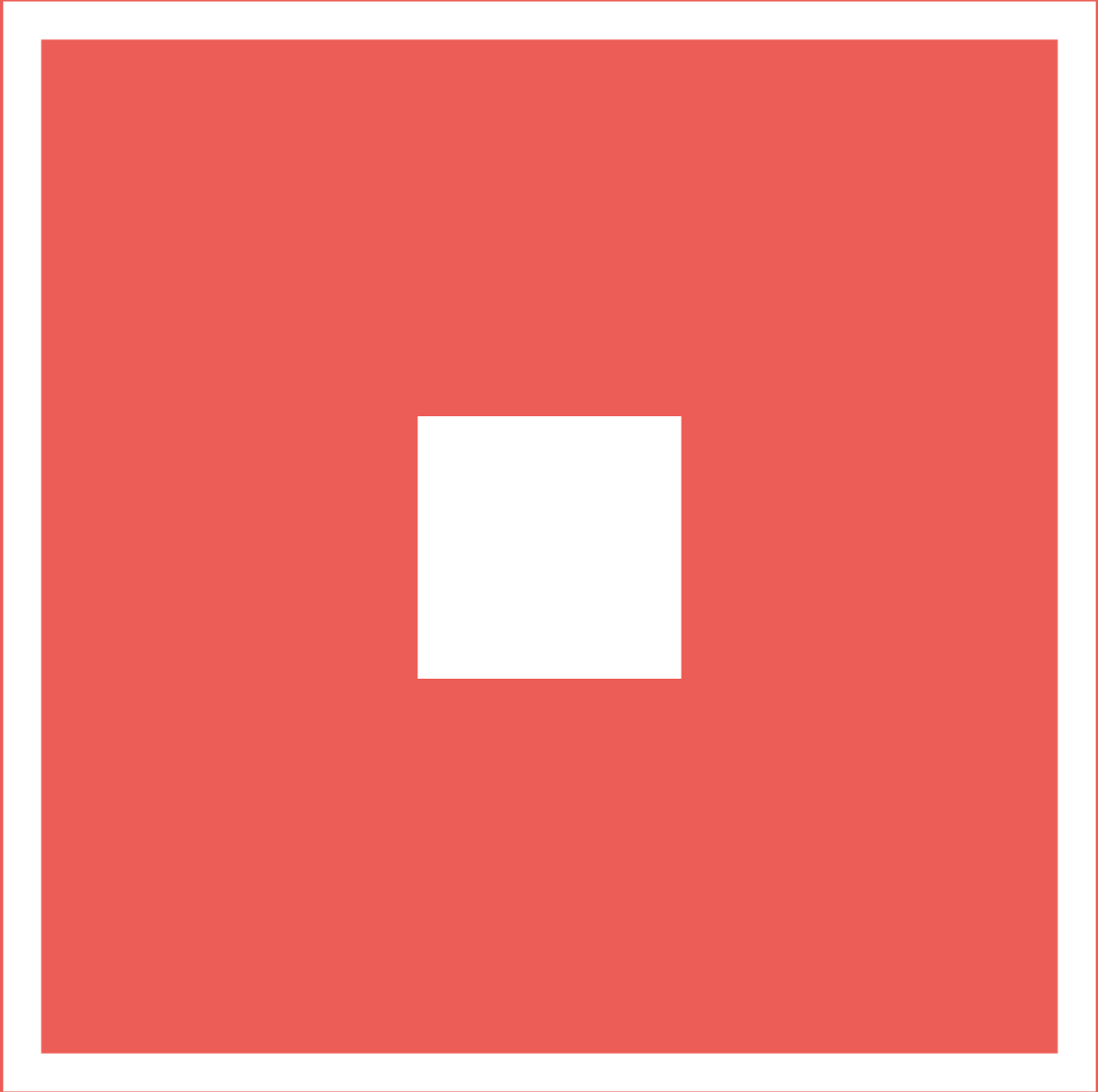





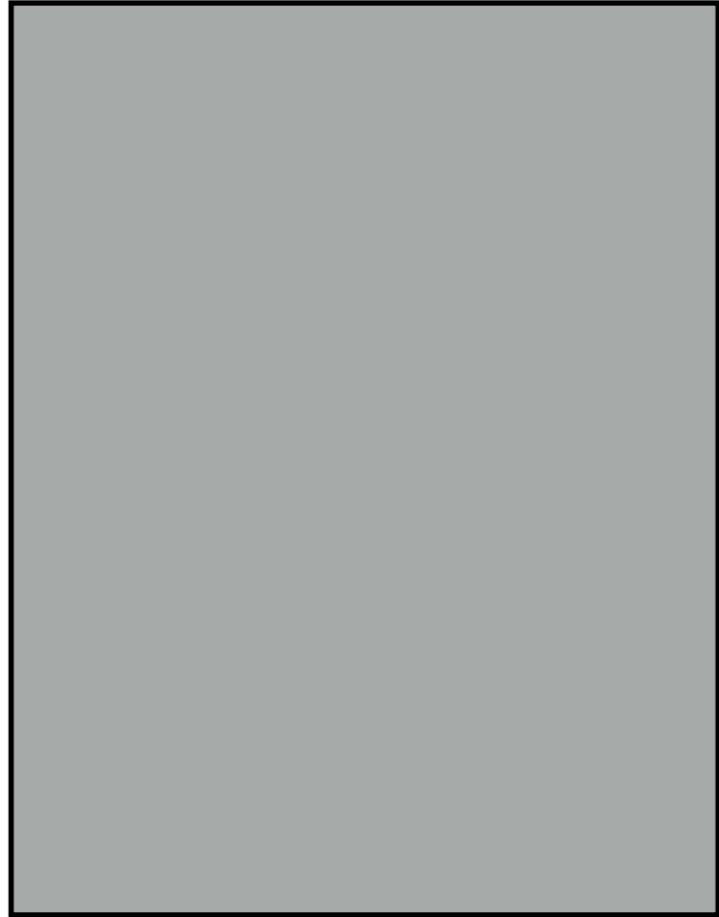
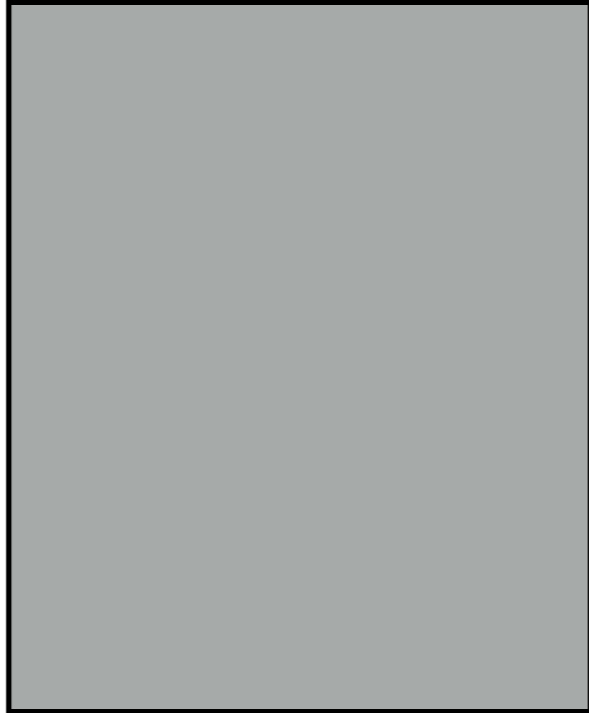
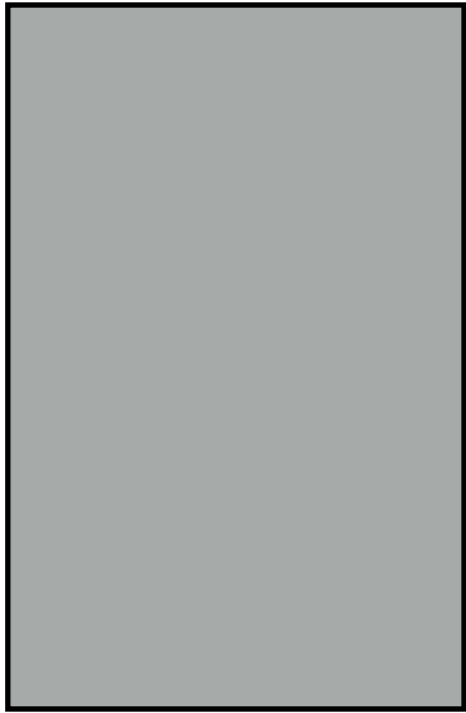

DIVINE SERVICE

The Lutheran church is a liturgical church. Lutherans believe that the gospel is not only good news that Jesus has saved sinners, but also a power God uses to create and strengthen faith in Jesus. Lutheran worship places the gospel in central focus in an order of service called the liturgy. In message and meal (Holy Communion), in specially selected Bible readings, and in carefully crafted songs, prayers, and confessions, the liturgy points to Jesus as the Savior of all.

WELCOME

OPENING HYMN

Praise To The Lord, The Almighty | 234

INVOCATION

Please stand

M In the name of the Father and of the + Son and of the Holy Spirit.

C Amen.

CONFESSION & ABSOLUTION

M Beloved in the Lord: let us draw near with a true heart and confess our sins to God our Father, asking him in the name of our Lord Jesus Christ to grant us forgiveness.

C Holy and merciful Father, I confess that I am by nature sinful and that I have disobeyed you in my thoughts, words, and actions. I have done what is evil and failed to do what is good. For this I deserve your punishment both now and in eternity. But I am truly sorry for my sins, and trusting in my Savior Jesus Christ, I pray: Lord, have mercy on me, a sinner.

LORD, HAVE MERCY

Lord, have mer-cy on us. Christ, have mer-cy
on us. Lord, have mer-cy on us. A - men.

M God, our heavenly Father, has been merciful to us and has given his only Son to be the atoning sacrifice for our sins. Therefore, as a called servant of Christ and by his authority, I forgive you all your sins in the name of the Father and of the Son + and of the Holy Spirit.

C Amen.

M In the peace of forgiveness, let us praise the Lord.

GLORY TO GOD

Sung to the tune of OLD HUNDREDTH

♪ All glory be to God on high!
Your name, O Lord, we glorify;
We praise you for your peace and grace,
Your favor toward our fallen race.

Our grateful thanks to you we bring,
For your great glory, heav'nly King,
For all, O Father, you have done
Through Jesus Christ, your only Son.

Papyrus

Comic Sans

Times New Roman

Fonts

Fonts



1 Stanza/Response text



THE SAVIOR'S SERMON

Honor Life & Marriage

"You have heard that it was said to the people long ago, 'You shall not murder,[a] and anyone who murders will be subject to judgment.' But I tell you that anyone who is angry with a brother or sister will be subject to judgment. Again, anyone who says to a brother or sister, 'Raca,' is answerable to the court. And anyone who says, 'You fool!' will be in danger of the fire of hell.

"Therefore, if you are offering your gift at the altar and there remember that your brother or sister has something against you, leave your gift there in front of the altar. First go and be reconciled to them; then come and offer your gift.

"Settle matters quickly with your adversary who is taking you to court. Do it while you are still together on the way, or your adversary may hand you over to the judge, and the judge may hand you over to the officer, and you may be thrown into prison. Truly I tell you, you will not get out until you have paid the last penny.

"You have heard that it was said, 'You shall not commit adultery.' But I tell you that anyone who looks at a woman lustfully has already committed adultery with her in his heart. If your right eye causes you to stumble, gouge it out and throw it away. It is better for you to lose one part of your body than for your whole body to be thrown into hell. And if your right hand causes you to stumble, cut it off and throw it away. It is better for you to lose one part of your body than for your whole body to go into hell.

"It has been said, 'Anyone who divorces his wife must give her a certificate of divorce.' But I tell you that anyone who divorces his wife, except for sexual immorality, makes her the victim of adultery, and anyone who marries a divorced woman commits adultery.

"Again, you have heard that it was said to the people long ago, 'Do not break your oath, but fulfill to the Lord the vows you have made.' But I tell you, do not swear an oath at all: either by heaven, for it is God's throne; or by the earth, for it is his footstool; or by Jerusalem, for it is the city of the Great King. And do not swear by your head, for you cannot make even one hair white or black. All you need to say is simply 'Yes' or 'No'; anything beyond this comes from the evil one. (NIV)

BOOKLETS

PLANNING

RESOURCES

ianmwelch.com/nwc